

Title: LTE-A TDD C-Band and MW backhaul Proof of Concept (PoC)

MCNS has successfully undertaken a Proof of concept (PoC) initial project phase, for a project named as “Rural Connect, Greece, Implementation and Support of Hybrid NGA” for a Greek Telecom consortium named as “Rural Connect SA” in Greece. This consortium is the joined effort of Net Company – Intrasoft S.A, Intrakat SA, and MCNS .

MCNS in the framework of this project prepared with the equipment’s vendor a proper test lab environment fully equipped with LTE-TDD RAN and MW equipment, in order to evaluate the equipment performance, test and stress the equipment under different planning scenarios and conditions, test the available optional features and finally decide on the most proper parameter configuration set for the next phase of network planning and deployment.

MCNS project deliverable was a PoC technical documentation with different sub-sections related to:

- LTE TDD indoor unit optional features and parameter evaluation, with a proposal for the most proper network hardware topology, parameter configuration set and necessary optional feature evaluation (i.e. scheduler performance, Link adaptation BER/BLER performance under different SINR conditions, scheduler service priorities, admission control and QCI/ARP etc) to support the equipment performance.

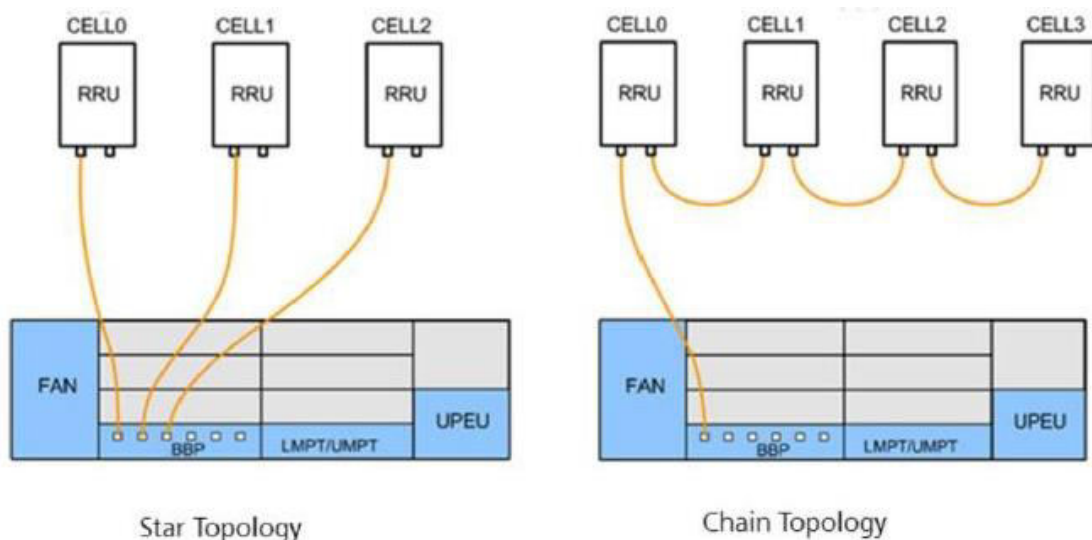

- Evaluation of 2x2 MIMO vs. 4x4 MIMO and 8x8 MIMO for different service throughput requirements vs. different network planning and deployment scenarios. Lab Tests were also supported by several drive test measurements in different network environments.

The proper Transmission Mode with most appropriate Transmission Scheme was proposed per case.

- MW equipment for point to point links evaluation, Different outdoor units (ODU) and antenna types were tested under different radio conditions, with the activation of several operational features and different parameter configuration settings.

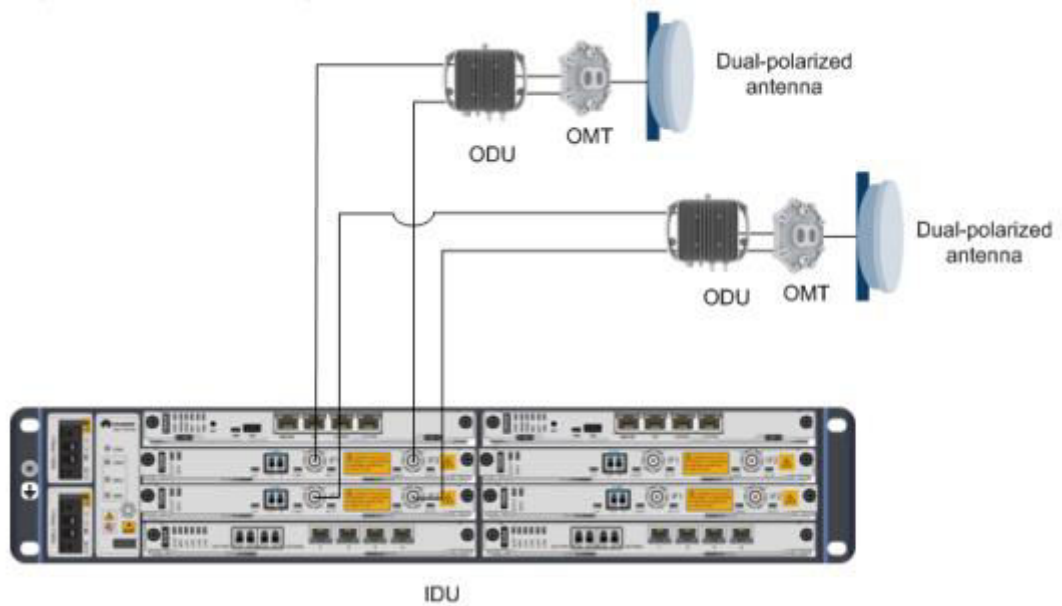

A final proposal of indoor unit (IDU) configuration set to maximize link capacity (throughput) and outdoor unit (ODU) parameter settings was reported

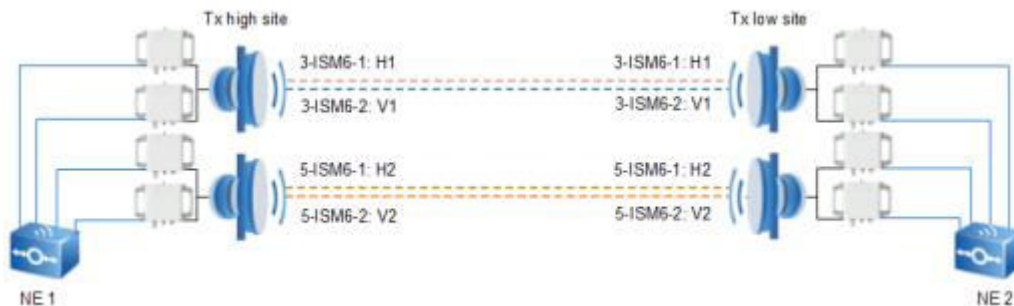

For further information about the affiliated company press [here](#).